

Extreme Temperature ARM® Cortex®-M0 Microcontroller VA10800

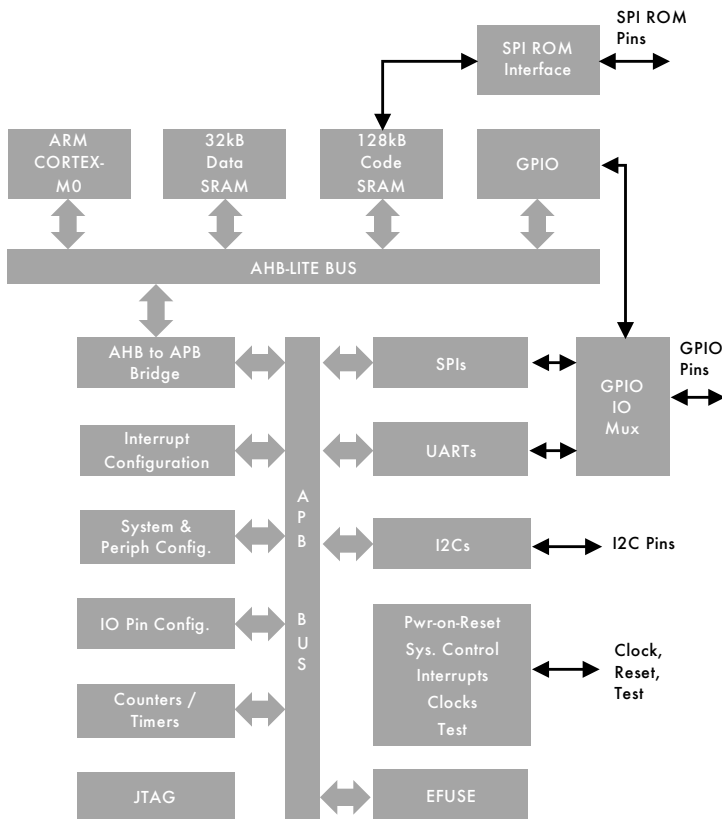

**32-Bit ARM® Cortex®-M0
Microcontroller manufactured with
HARDSIL® technology offering
superior operational lifetimes,
low leakage performance and
latch-up protection at extreme
temperatures up to 200°C.**



KEY FEATURES

- Manufactured with HARDSIL® technology
- 32-bit ARM® Cortex®-M0 processor
 - JTAG based debug interface
- Operating voltages
 - Core voltage 1.5 +/- 0.15V
 - I/O voltage 3.3 +/- 0.33V
- Clock rate 50MHz
- Memory
 - 32KB on-chip data and 128KB on-chip program memory
 - 1KB Efuse for custom boot and unique ID support
- Peripherals
 - 54 configurable GPIO pins
 - 2 UART interfaces
 - 2 I2C interfaces
 - 3 SPI interfaces (2 master / slave, 1 master)
- Timer System
 - 24 configurable 32-bit counters / timers
 - Input capture, Output compares
 - PWMs, Pulse Counters, Watchdog timer
- Package
 - Plastic or Ceramic 128 pin LQFP (14 x 14mm)
 - Die option available

EXTREME TEMPERATURE RANGE

- -55° to 200°C
 - Up to 1.1 years lifetime at 200°C

SUPPORT

- REB1 development board
- Keil™ MDK-ARM microcontroller software kit

APPLICATIONS

- Industrial
- Oil & Gas
- Medical
- Aerospace
- Automotive

For more information, contact below or visit our web site at www.voragotech.com
 VORAGO Technologies | 1501 S MoPac Expressway, Suite 350, Austin, Texas, 78746 | info@voragotech.com

MCU ORDERING INFORMATION

| Description | Part number | Environment | Temperature Range | Package |
|-------------------------------------|--------------------|---------------------|-------------------|------------------|
| Extreme temperature microcontroller | VA10800-D000003PCA | Extreme temperature | -55° to 200°C | Die |
| Extreme temperature microcontroller | VA10800-CQ12803ECA | Extreme temperature | -55° to 200°C | Ceramic 128 LQFP |
| Extreme temperature microcontroller | VA10800-PQ12803PCA | Extreme temperature | -55° to 200°C | Plastic 128 LQFP |

DEVELOPMENT BOARD ORDERING INFORMATION

| Description | Part number | Features |
|-------------------|--------------|--|
| Development Board | REB1-VA10800 | Supported by Keil™ MDK-ARM Microcontroller Software Kit Board Support Package (BSP) includes example software for peripherals Segger J-Link OB |

REB1-VA10800 DEVELOPMENT BOARD BLOCK DIAGRAM

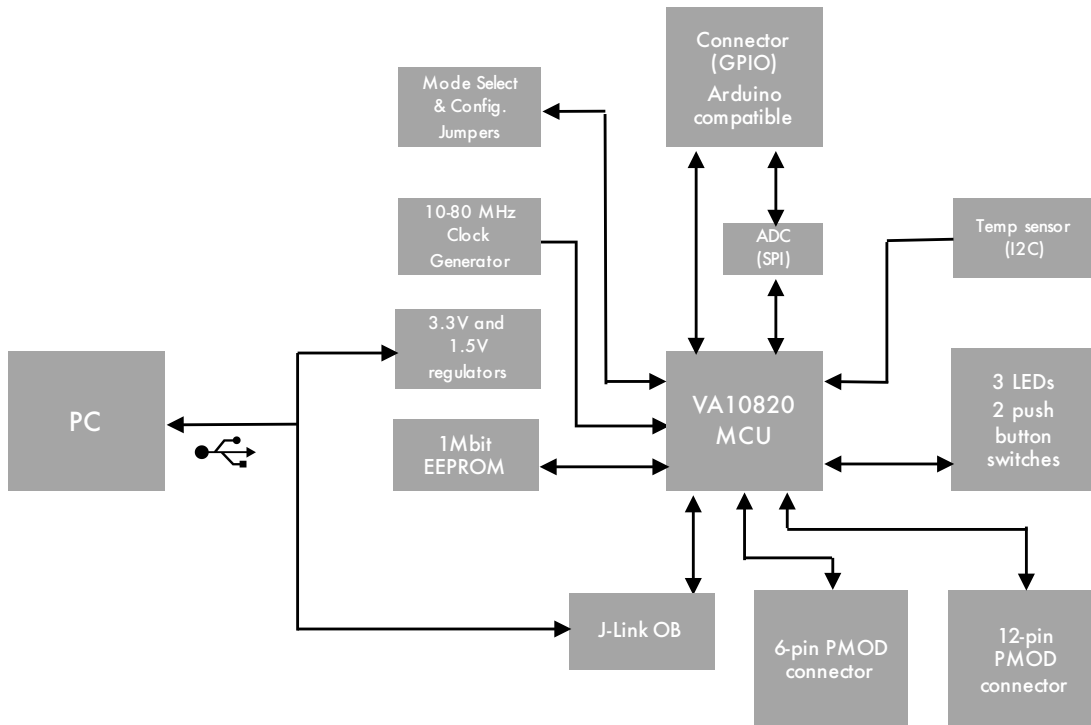

For more information, contact below or visit our web site at www.voragotech.com
 VORAGO Technologies | 1501 S MoPac Expressway, Suite 350, Austin, Texas, 78746 | info@voragotech.com